

## PRODUCT OVERVIEW

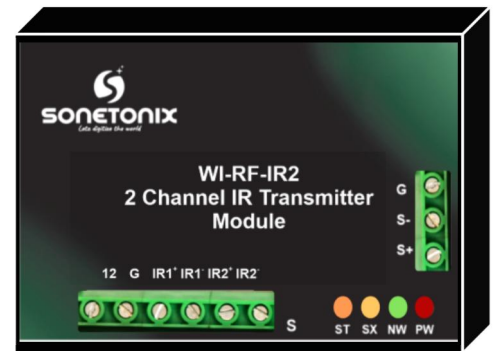

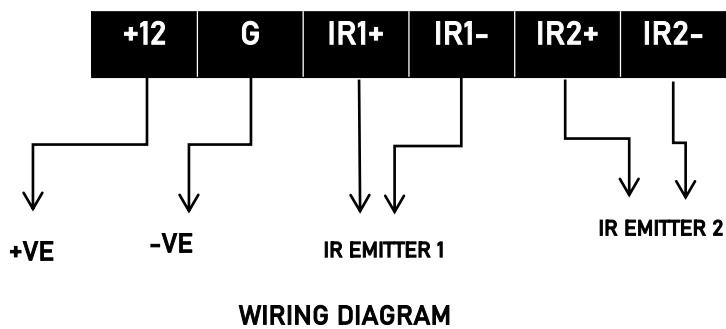

Sonetonix WiFi Smart device controlling your lighting & Home appliances. The whole system goes on your wall accompanied by insert Switchboard Modules which sit behind your existing switchboards. The switchboard module enables your appliances to communicate with the Brain of the system, which acts as a connectivity hub, letting you control your appliances through the Smart phone app



## TECHINICAL SPECIFICATION

Combination	<ul style="list-style-type: none"> <li>0 Humming free fan</li> <li>0 Dimmable load</li> <li>0 Normal load</li> <li>0 Heavy load</li> </ul>
Operating input voltage	+12 VDC
IR frequency	20-50 kHz
Communication protocol	Wi-Fi/2.4GHz/RS-485
Ranga (Line of Sight)	8 Meter
Wi-Fi signal strength min	» 50 %
Operating temperature	0°C - 45°C
Product size	84mmx 54mm x 25mm
Shockproof	No
Water resistance	No

## FEATURES

- 
Anti-shock switching
- 
Hassle free installation & No rewiring
- 
OTA update support
- 
Optional RS-485 communication
- 
Easy control of all type of devices